

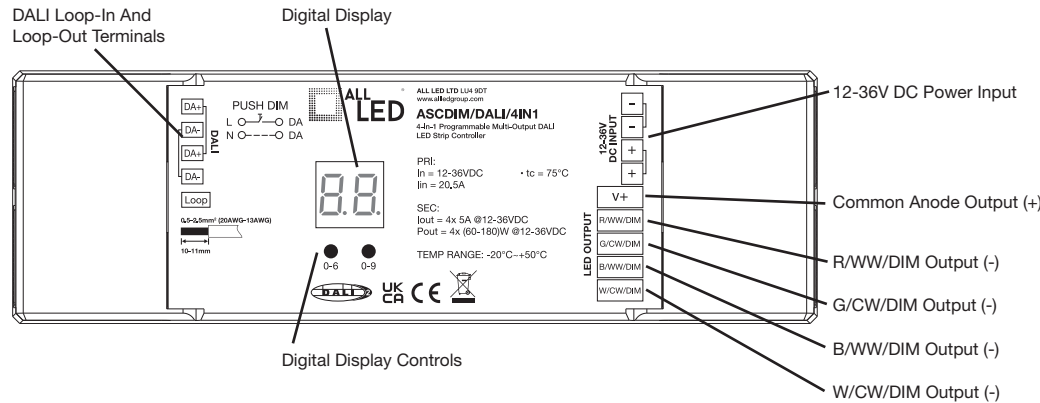

INSTALLATION GUIDE ASCDIM/DALI/4IN1

Product Installation Guide



Product Information

Input Voltage	Output Current	Output Power	Remarks	Size (LxWxH)	DALI Consumption	Dimming Range	Ambient Temperature
12-36VDC	4x5A	4x (60-180)W	Constant voltage	170x53.4x28mm	2mA	0.1%-100%	-20°C ~ +50°C

Dimensions

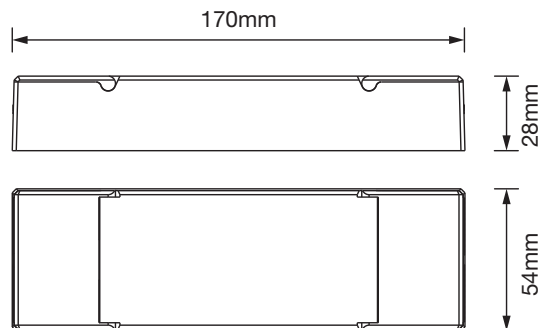

Operation

1. Select a DALI Device Type

- 1.1. Press and hold down both buttons until digital display flashes, then release the button.
- 1.2. Keep clicking the 2nd button, you will get the 8 device types one by one as follows, 6 of them are valid modes, please ignore the other 2 modes which are invalid here:

- Tc** means 2 Tc colour type devices integrated in one control gear, which can control 2 groups of tunable white LED separately using 2 DALI addresses under this mode.
- Hc** (invalid mode since this mode requires 5 PWM channels), means XY & Tc colour type devices integrated in one control gear, which can control RGB & CCT LED separately using 2 DALI addresses under this mode.
- r.c** (invalid mode since this mode requires 5 PWM channels), means RGBWAF & Tc colour type devices integrated in one control gear, which can control RGB & CCT LED separately using 2 DALI addresses under this mode.
- Hb**, means XY & DT6 type devices integrated in one control gear, which can control RGB & W LED separately using 2 DALI addresses under this mode.
- H4**, means XY coordinate colour type, which can control RGB LED using 1 DALI address under this mode.
- Tc**, means Tc colour type, which can control tunable white LED using 1 DALI address under this mode.
- r9**, means RGBWAF colour type, the device can control RGBW LED using 1 DALI address under this mode.
- T6**, means DT6 device type, which can control single colour LED using 1 DALI address under this mode.

- 1.3. Select a device type you would like and then press and hold down both buttons until digital display stops flashing to confirm the selection.

2. Setting a DALI Address

This device by default is set to no DALI address. To set the address up please read below. Available DALI Addresses are 00-63.

Press and hold down the right hand button until the digital display flashes, then release.

- 2.1. By pressing the buttons, scroll through the numbers until the desired address has been set.
- 2.2. Press and hold down the right button until the digital display stops flashing to save the settings.

Note: DALI address can be manually assigned from 00-63. The factory default setting is that no DALI address is assigned to the unit. To Factory reset the device select **FF** on the digital display.

Note: Should a DALI master be used to set the address on the controllers, the digital display will read **AU**

3. Push Dimming Mode

While connected with an AC push switch, the digital display will show **Pd** which means Push Dimmer Mode, operations under Push Dimmer Mode are as follows:

- While **Tc** device type is selected, only the 1st group tunable white LED will be controlled by the push switch,
 - Click the button to switch ON/OFF
 - Press and hold down the button to increase or decrease light intensity to desired level and release it, then repeat the operation to adjust light intensity to opposite direction. The dimming range is from 1% to 100%.
 - Double click the button to switch between brightness mode and colour temperature mode.
 - Press and hold down the button to change colour temperature under colour temperature mode.

While **H5** device type is selected, only the RGB LED will be controlled by the push switch,

- Click the button to switch ON/OFF
- Press and hold down the button to increase or decrease light intensity to desired level and release it, then repeat the operation to adjust light intensity to opposite direction. The dimming range is from 1% to 100%.
- Double click the button to switch between brightness mode and RGB colour mode.
- Press and hold down the button to change RGB colours under RGB colour mode.



While **44** or **74** device type is selected, RGB LED will be controlled by the push switch,

- Click the button to switch ON/OFF
- Press and hold down the button to increase or decrease light intensity to desired level and release it, then repeat the operation to adjust light intensity to opposite direction. The dimming range is from 1% to 100%.
- Double click the button to switch between brightness mode and RGB colour mode.
- Press and hold down the button to change RGB colours under RGB colour mode.

While **7C** device type is selected, tunable white LED will be controlled by the push switch,

- Click the button to switch ON/OFF
- Press and hold down the button to increase or decrease light intensity to desired level and release it, then repeat the operation to adjust light intensity to opposite direction. The dimming range is from 1% to 100%.
- Double click the button to switch between brightness mode and colour temperature mode.
- Press and hold down the button to change colour temperature under colour temperature mode.

While **76** device type is selected, single colour LED will be controlled by the push switch,

- Click the button to switch ON/OFF
- Press and hold down the button to increase or decrease light intensity to desired level and release it, then repeat the operation to adjust light intensity to opposite direction. The dimming range is from 1% to 100%.

Memory function after power off or power failure enables the device to memorize the status before power off while power on again.

DALI Wiring Diagrams

1. With DALI Master

1.1 When **7c** multi-addresses Tc device type selected

1.1.1 When total load of each receiver is not over 10A

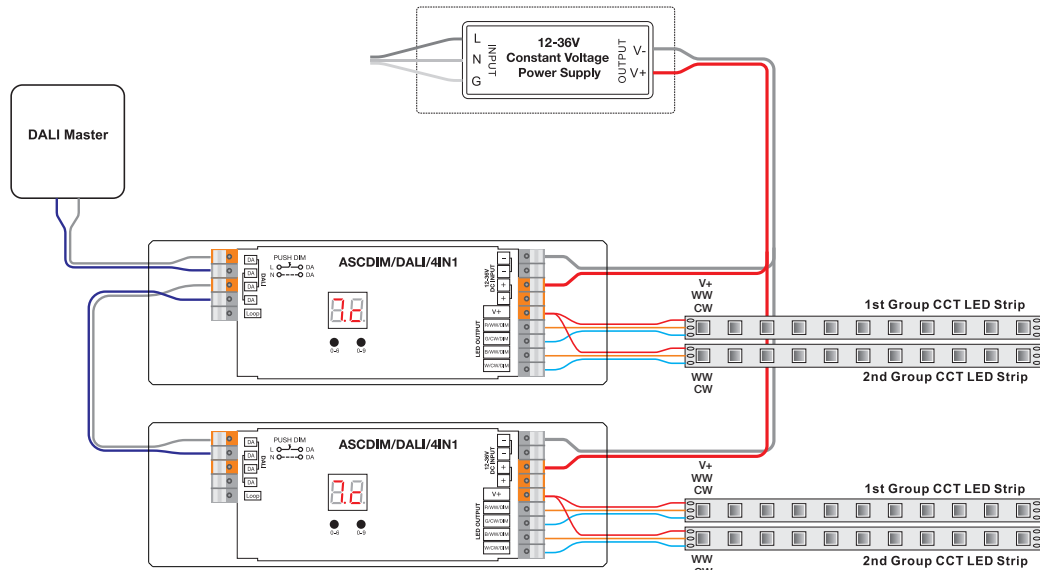

1.1.2 When total load of each receiver is over 10A

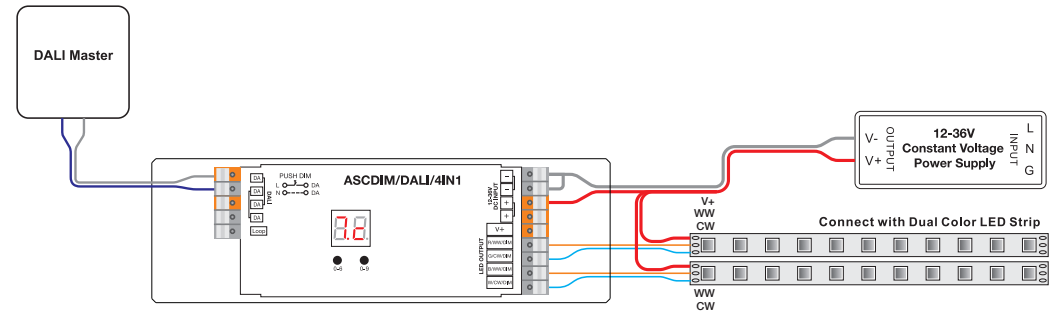

- Note: 1) Please make sure that the DALI master controller supports Tc colour type commands.
2) The control gear will be discovered by master controller as 2 separate Tc devices.

1.2 When **4.6** multi-addresses XY+Single Colour(DT6) device type selected

1.2.1 When total load of each receiver is not over 10A

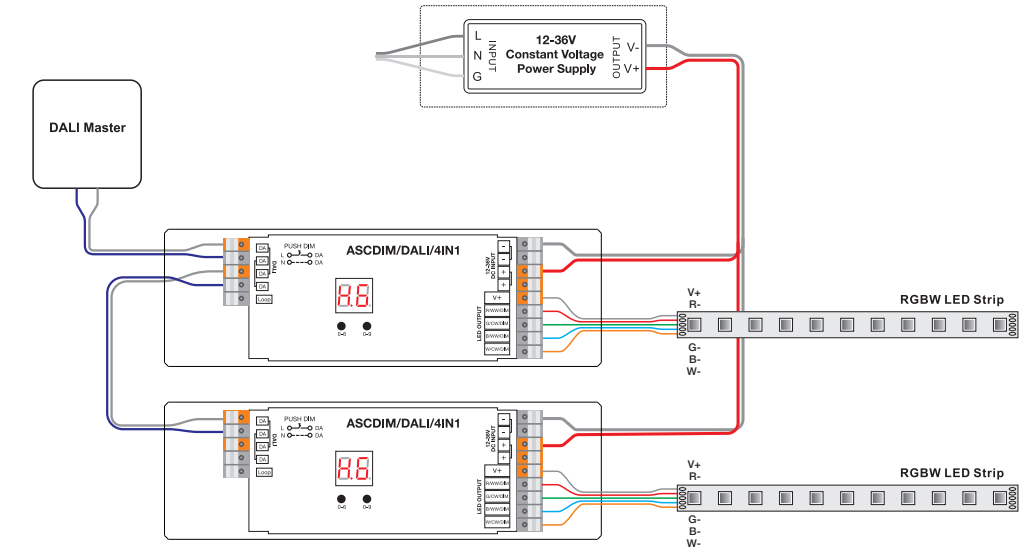

1.2.2 When total load of each receiver is over 10A

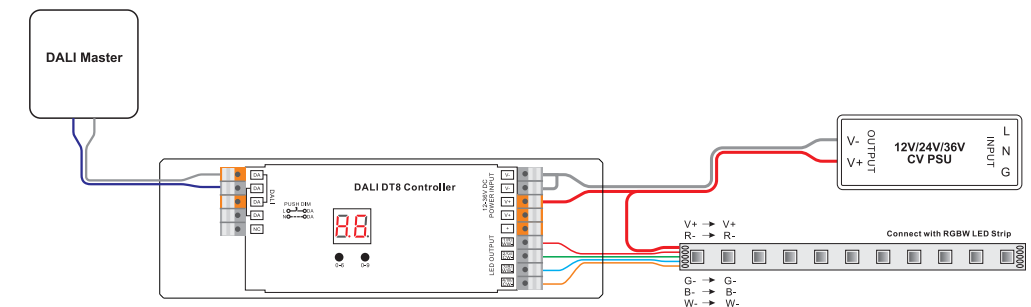

- Note: 1) Please make sure that the DALI master controller supports XY & DT6 colour type commands.
2) The control gear will be discovered by master controller as 2 separate devices: XY, DT6

1.3 When **H4** single-address XY device type selected

1.3.1 When total load of each receiver is not over 10A

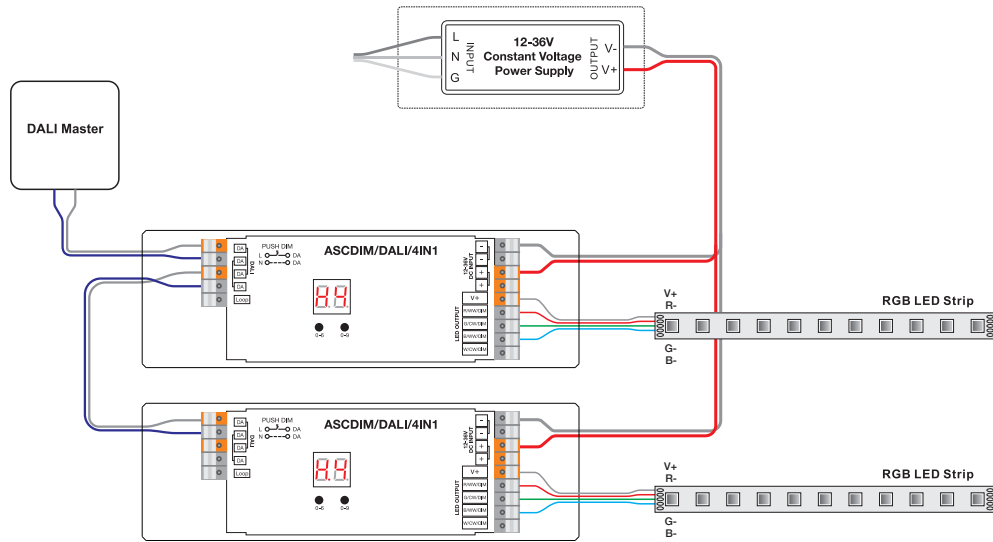

1.3.2 When total load of each receiver is over 10A

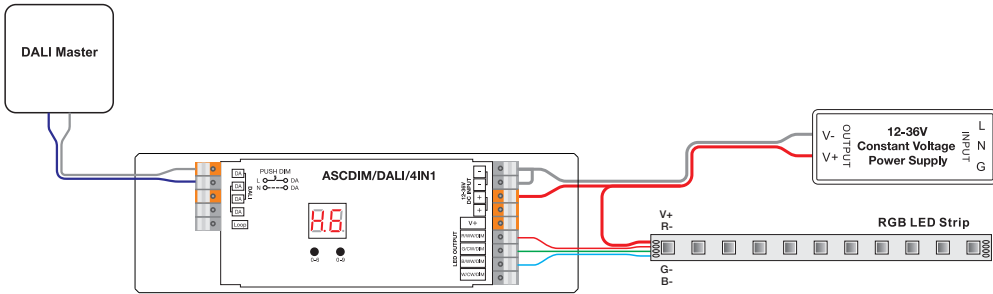

Note: Please make sure that the DALI master controller supports XY colour type commands.

1.4 When **Tc** single-address Tc device type selected

1.4.1 When total load of each receiver is over 10A

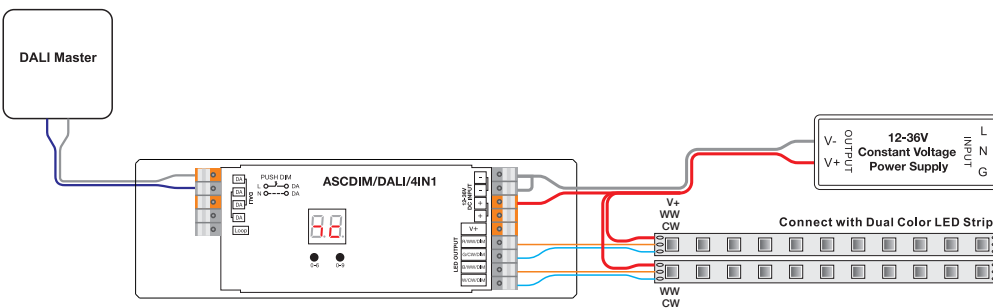

1.4.2 When total load of each receiver is not over 10A

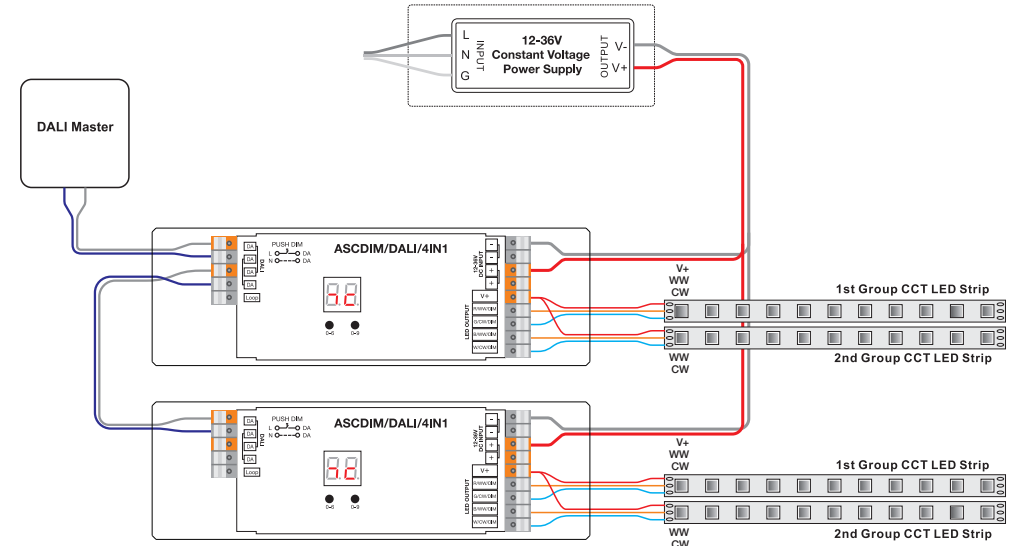

Note: 1) Please make sure that the DALI master controller supports Tc colour type commands.
2) 2 groups CCT LED are controlled together.

1.5 When **r9** single-address RGBWAF device type selected

1.5.1 When total load of each receiver is not over 10A

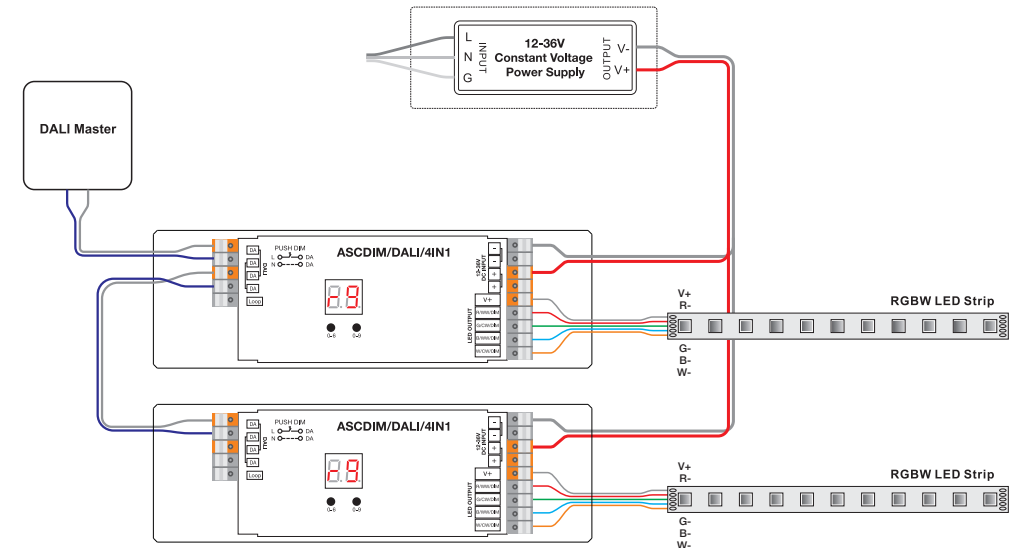

1.5.2 When total load of each receiver is over 10A

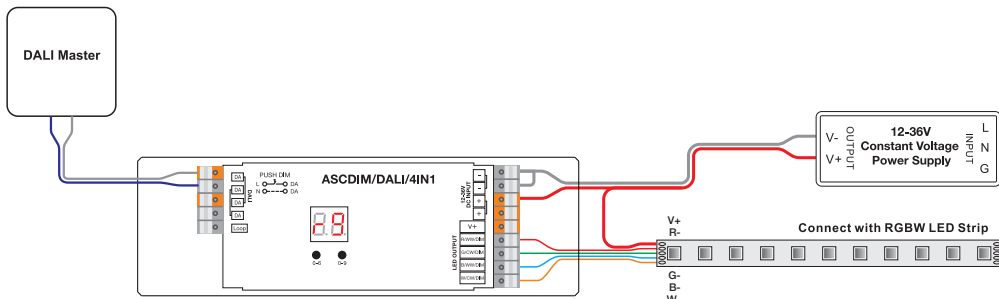

Note: Please make sure that the DALI master controller supports RGBWAF colour type commands.

1.6 When **7.6** single-address DT6 device type selected

1.6.1 When total load of each receiver is not over 10A

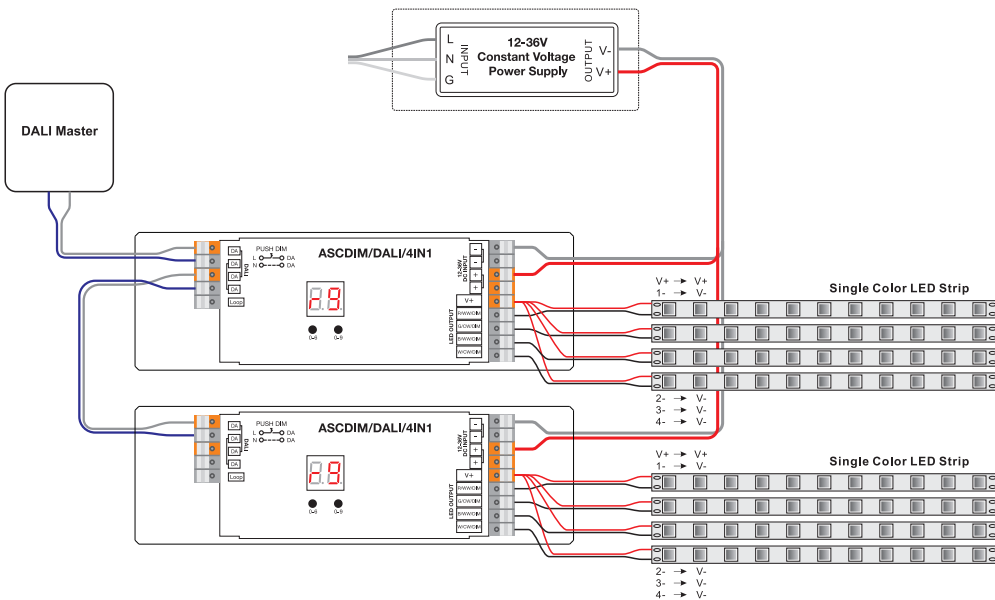

1.6.2 When total load of each receiver is over 10A

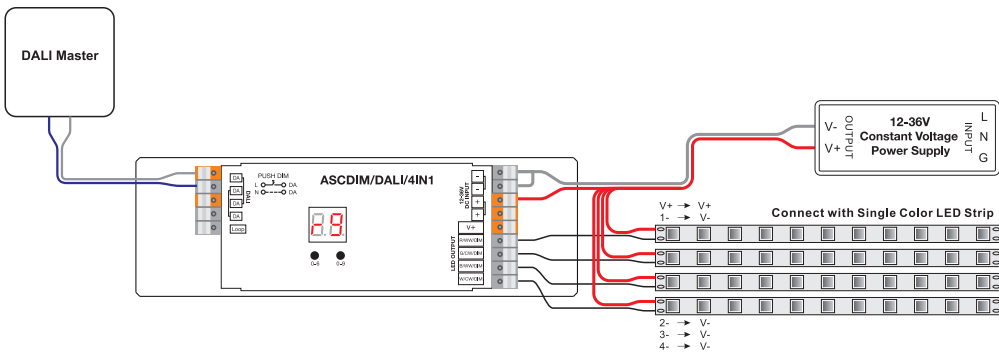

Note: The control gear will be discovered by DALI master as a DT6 device, 4 channels controlled together.

Retractive/Push Dimming Wiring Diagrams

2.1 When **7.6** multi-addresses Tc device type selected

2.1.1 When total load of each receiver is not over 10A

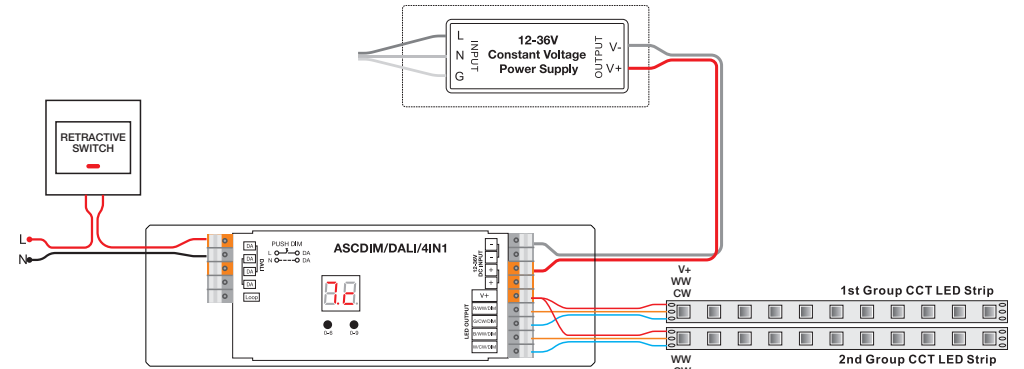

2.1.2 When total load of each receiver is over 10A

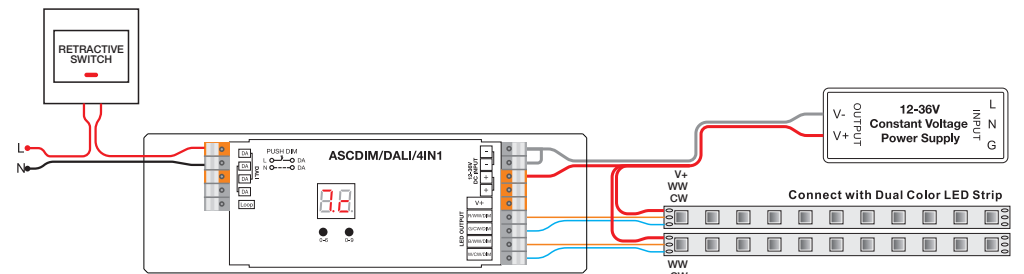

Note: only the 1st group CCT LED can be controlled under this mode.

2.2 When **4.6** multi-addresses XY+Single Colour(DT6) device type selected

2.2.1 When total load of each receiver is not over 10A

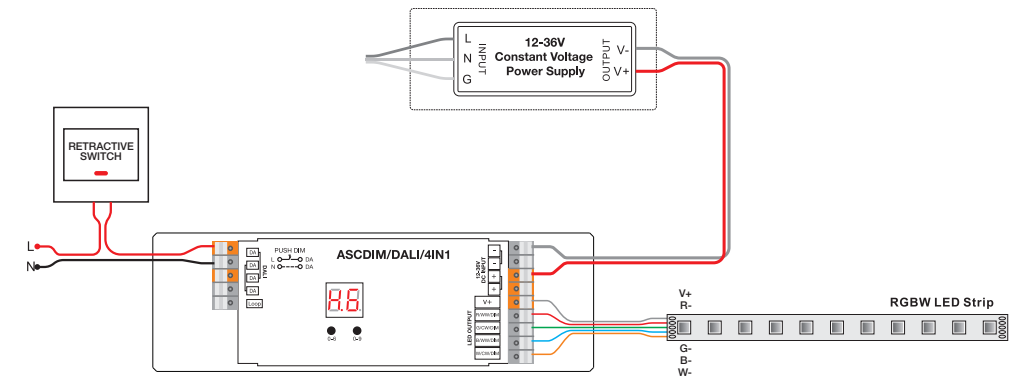

2.2.2 When total load of each receiver is over 10A

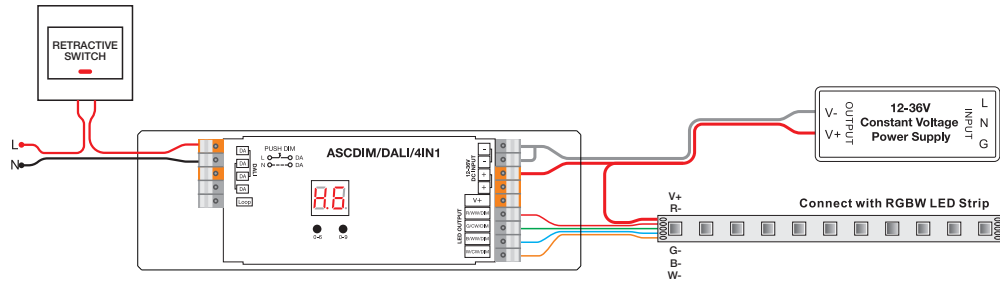

Note: only the RGB LED can be controlled under this mode.

2.3 When **H4** single-address XY device type selected

2.3.1 When total load of each receiver is not over 10A

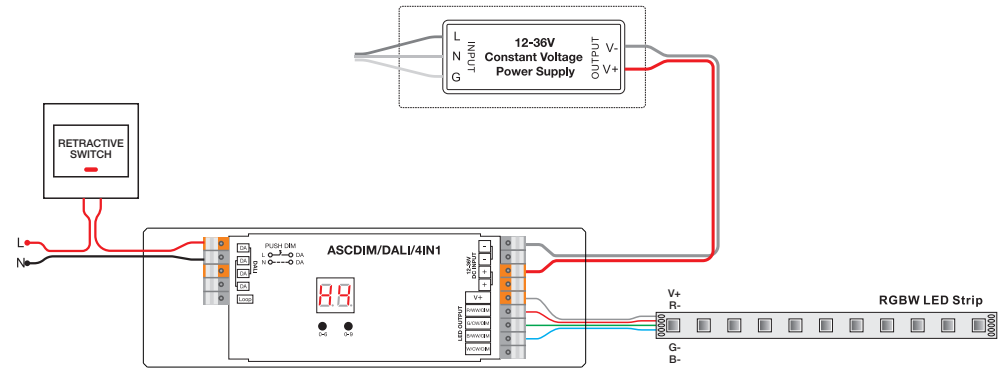

2.3.2 When total load of each receiver is over 10A

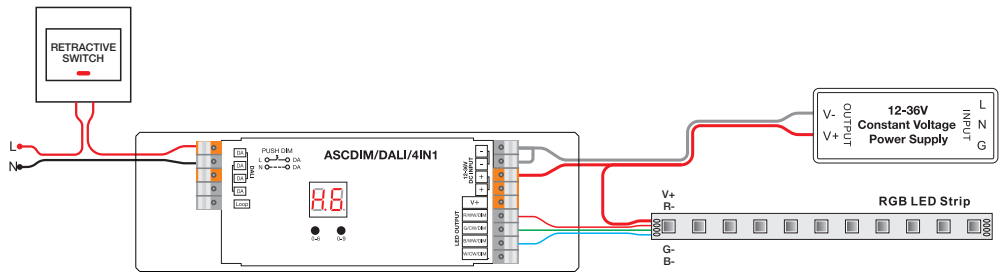

2.4 When **7C** single-address Tc device type selected

2.4.1 When total load of each receiver is over 10A

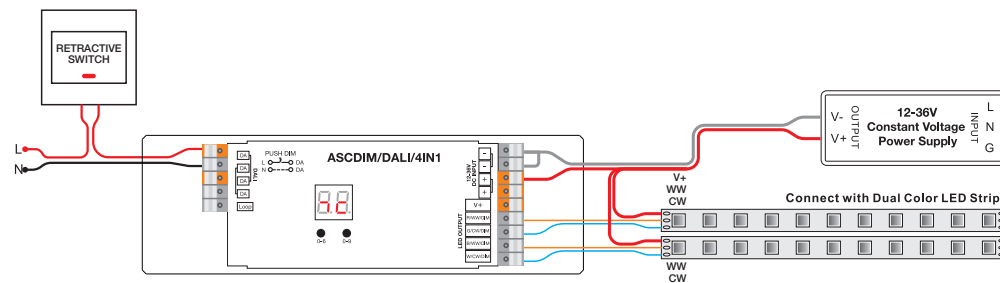

2.4.2 When total load of each receiver is not over 10A

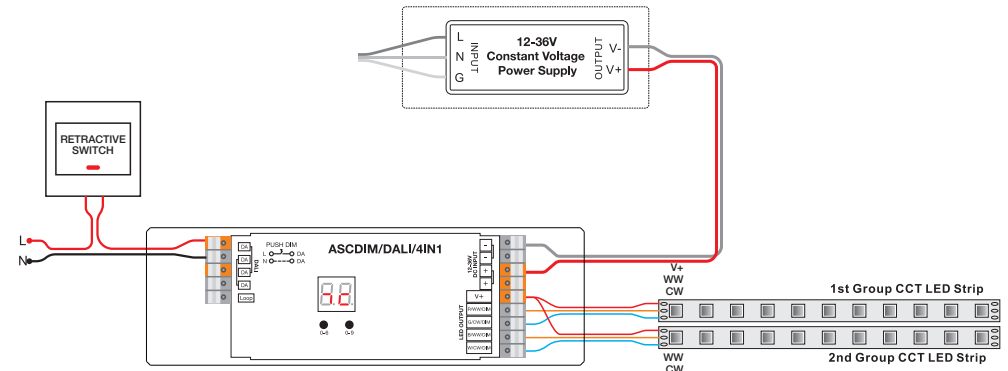

Note: 2 groups CCT LED are controlled together under this mode.

2.5 When **r9** single-address RGBWAF device type selected

2.5.1 When total load of each receiver is not over 10A

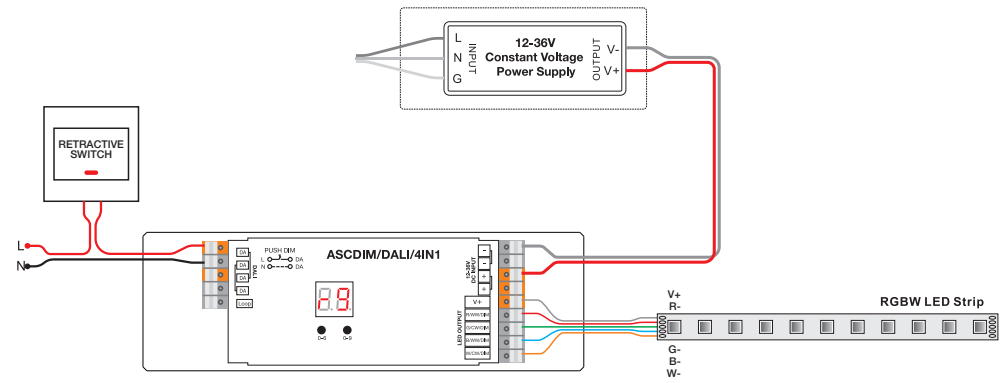

2.5.2 When total load of each receiver is over 10A

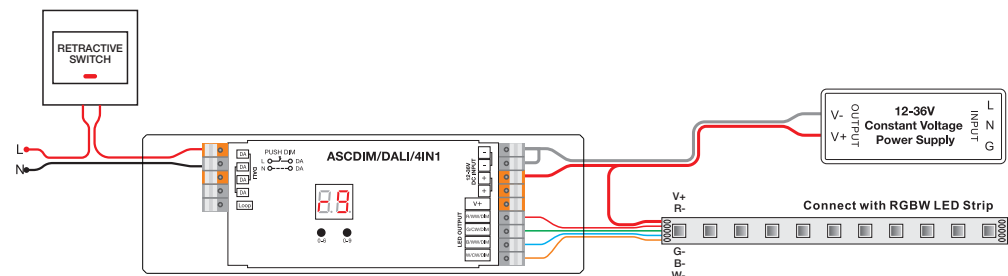

Note: brightness of both RGB & W LEDs can be controlled, colour control only applicable to RGB LED under this mode.

2.6 When 76 single-address DT6 device type selected

2.6.1 When total load of each receiver is not over 10A

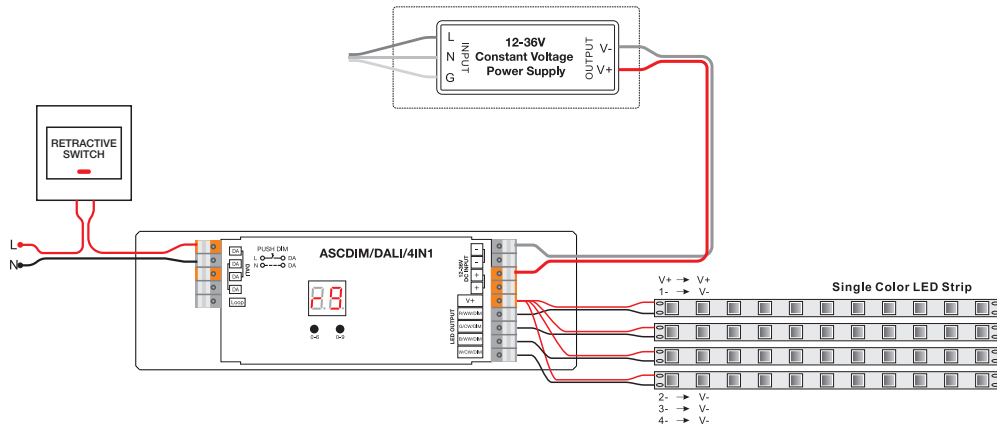

2.6.2 When total load of each receiver is over 10A

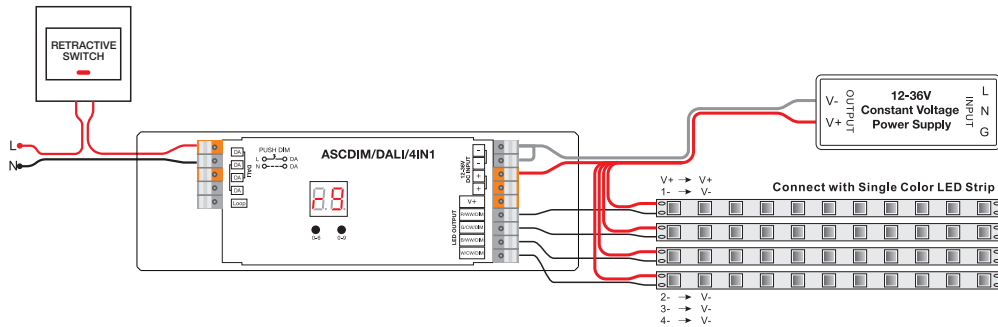

Safety

- Do not cover the ground contact.
- Do not place any material over the lens or LED diode/chip.
- Do not insert objects into the luminaire.
- Do not clean using any solvent based abrasive or aggressive product.
- Do not pull any cables connected to the product.
- Do not direct the luminaire into a person's eyes, as this unit may have an intense light output, which if incorrectly used may cause eye damage.
- Light engines/LEDs and other light sources may heat up, please take care when handling the products.
- The manufacturer will not be deemed liable or held responsible for any damages caused by faults or manufacturing defects that may be present in any of its products or the misuse or incorrect installation of this device.
- The manufacturer will not be held liable for any death(s) or injuries caused by misuse or poor installation or any unreported faults of this product version or versions thereof.
- LEDs are sensitive to electrostatic discharge. Do not touch the surface of any LED module.
- Do not connect to a temporary electricity supply, this may damage any electronics.
- Light fittings with an integrated emergency option come with a separate installation and wiring leaflet. Please refer to this manual for further details. If the manual is unavailable please contact an ALL LED representative for assistance.

Returns & Faulty Items

- If any problem is encountered during or after installation, please call ALL LED technical department to get the problem resolved as soon as possible.
- Please do not just return the item to the outlet you purchased it from, as you are only entitled to a replacement or refund after the unit has undergone testing and the unit has been confirmed as having a manufacturing defect/fault. Your statutory rights are not affected.
- The manufacturer will not be deemed liable or held responsible for any damages caused by faults or manufacturing defects that may be present in any of its products or the misuse or incorrect installation of this device. Please refer to our troubleshooting guide for further information.
- All installations must be carried out in accordance with this installation guide and user manual.
- All goods are supplied under the terms and conditions of ALL LED LTD, a copy of which may be obtained upon written request.

Environmental Protection
Waste electrical products should not be disposed of with household waste. Please recycle where facilities exist. Check with your Local Authority or retailer for recycling advice.



ISOLATE MAINS SUPPLY
BEFORE HANDLING ANY
ELECTRICAL PRODUCTS



ALL LED LTD
42 Sedgwick Road,
Luton, LU4 9DT

www.allledgroup.com
sales@allledgroup.com
Tel: +44 (0)208 841 9000

This product supplied with a limited 2 year guarantee, subject to terms and conditions. The manufacturer will not be deemed liable or held responsible for any damages caused by faults or manufacturing defects that may be present in any of its products or the misuse or incorrect installation of this device. Your statutory rights are not affected.

